

## 6.4 Грузовые цепи с повышенными пластинами, DIN 8165/8167

Конвейерные цепи со сплошными валиками  
Грузовые цепи с повышенными пластинами

Тип FVT DIN 8165, часть 3

Лист 1/2

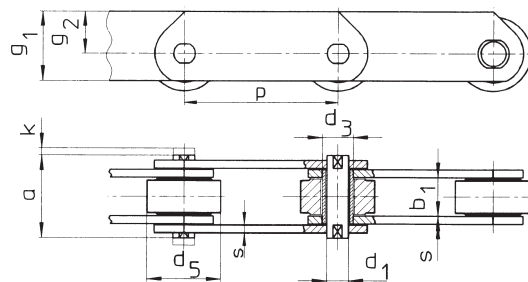

DIN-цепь №	Шаг	Ширина в свету	Валики	Втулки	Ролики	Общая ширина пластин	Высота над серединой цепи	Толщина пластин
	p		b <sub>1</sub>	∅ d <sub>1</sub>	∅ d <sub>3</sub>			
мм								
FVT 40	40 63 100	18	10	15	32	35	22,0	3
FVT 63	63 100 125 160	22	12	18	40	40	25,0	4
FVT 90	63 100 125 160 200 250	25	14	20	48	45	27,5	5
FVT 112	100 125 160 200 250	30	16	22	55	50	30,0	6
FVT 140	100 125 160 200 250 315	35	18	26	60	60	37,5	6
FVT 180	125 160 200 250 315 400	45	20	30	70	70	45,0	8
FVT 250	125 160 200 250 315 400	55	26	36	80	80	50,0	8
FVT 315	160 200 250 315 400	65	30	42	90	90	55,0	10
FVT 400	160 200 250 315 400	70	32	44	100	90	55,0	12
FVT 500	160 200 250 315 400 500	80	36	50	110	100	60,0	12
FVT 630	200 250 315 400 500	90	42	56	120	120	70,0	12

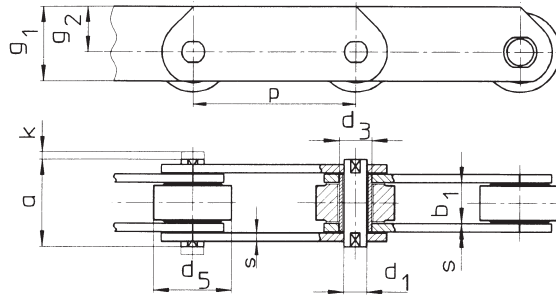

DIN- цепь №	Длина соед. заклепки а макс.	Выступ пальца с чекой к макс.	Предел прочности	Площадь шарнира	Удельное давление на шарнир, доп.	Вес
FVT 40	37	3,5	40	2,5	2680	5,54 4,12 3,20
FVT 63	46	4,5	63	3,7	2840	7,13 5,42 4,84 4,33
FVT 90	53	4,5	90	5,0	3000	11,15 8,33 7,37 6,53 5,93 5,45
FVT 112	63	4,5	112	6,8	2750	12,28 10,76 9,44 8,49 7,74
FVT 140	68	6,0	140	8,6	2720	15,91 13,86 12,06 10,78 9,75 8,91
FVT 180	86	7,0	180	12,3	2440	23,09 19,96 17,73 15,94 14,46 13,26
FVT 250	98	8,0	250	18,7	2230	32,08 27,26 23,82 21,06 18,79 16,93
FVT 315	117	8,0	315	25,8	2040	40,87 35,52 31,24 27,71 24,83
FVT 400	131	10,0	400	30,7	2170	51,41 44,52 39,01 34,46 30,74
FVT 500	141	10,0	500	38,2	2180	65,53 56,19 48,72 42,56 37,52 33,78
FVT 630	153	10,0	630	48,7	2160	74,77 64,34 55,73 48,69 43,47

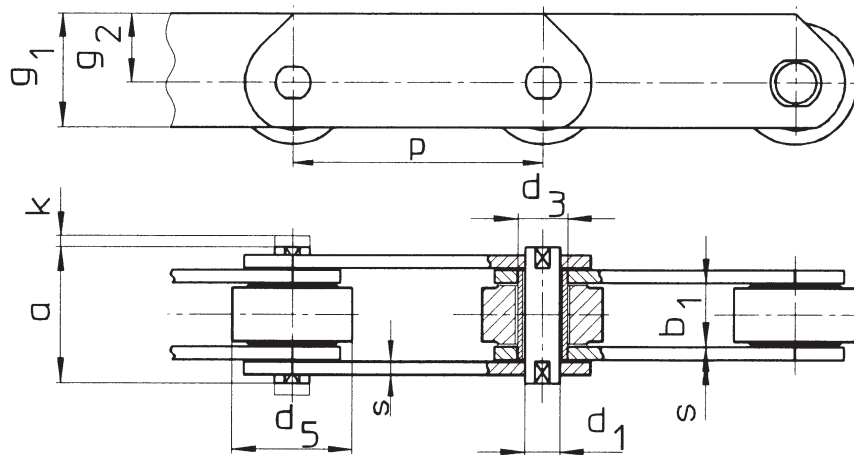

DIN- цепь №	Шаг	Ширина в свету	Валики	Втулки	Ролики	Общая ширина пластин	Высота над серединой цепи	Толщина пластин
	p	b <sub>1</sub>	∅ d <sub>1</sub>	∅ d <sub>3</sub>	∅ d <sub>5</sub>	g <sub>1</sub>	g <sub>2</sub>	s
	мм							
MT 20	40	16	6,0	9,0	25	25	16,0	2,5
	50							
	63							
	80							
	100							
	125							
MT 28	160	18	7,0	10,0	30	30	20,0	3,0
	200							
	250							
	315							
	400							
	500							
MT 40	63	20	8,5	12,5	36	35	22,5	3,5
	80							
	100							
	125							
	160							
	200							
MT 56	250	24	10,0	15,0	42	45	30,0	4,0
	315							
	400							
	500							
	630							
	800							
MT 80	80	28	12,0	18,0	50	50	32,5	5,0
	100							
	125							
	160							
	200							
	250							
315								

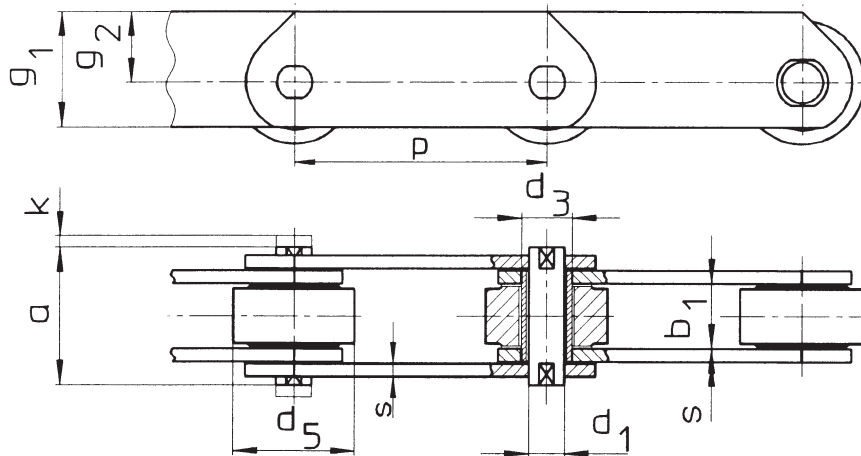

DIN- цепь №	Длина соед. заклепки а макс.	Выступ пальца с чекой к макс.	Предел прочности	Площадь шарнира	Удельное давление на шарнир, доп.	Вес
	мм		кН	см <sup>2</sup>	Н/см <sup>2</sup>	кг/м
МТ 20	35	7,0	20	1,32	2160	3,01
						2,61
						2,27
						2,00
						1,79
						1,63
МТ 28	40	8,0	28	1,75	2290	1,49
						4,02
						3,48
						3,04
						2,71
						2,45
МТ 40	45	9,0	40	2,38	2400	2,23
						2,06
						5,29
						4,58
						4,05
						3,62
МТ 56	52	10,0	56	3,30	2430	3,25
						2,99
						2,77
						8,39
						7,21
						6,33
МТ 80	62	12,0	80	4,68	2440	5,63
						5,02
						4,58
						4,23
						11,17
						9,72
8,56						
7,55						
6,82						
6,24						
5,76						

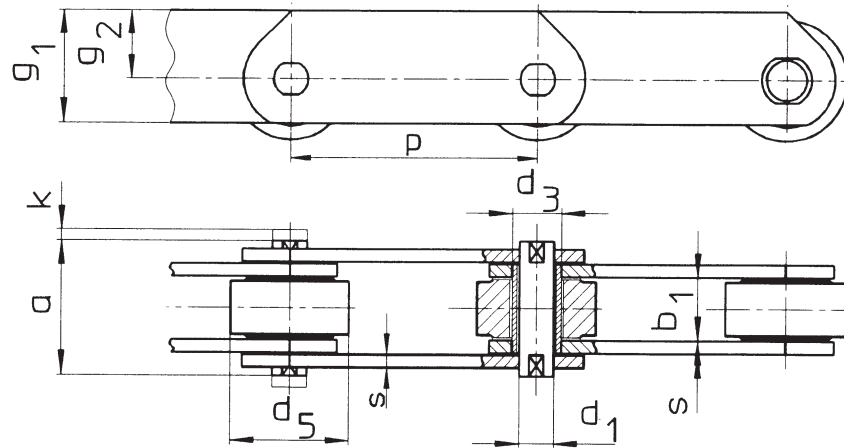

DIN- цепь №	Шаг	Ширина в свету	Валики	Втулки	Ролики	Общая ширина пластин	Высота над серединой цепи	Толщина пластин
	p	b <sub>1</sub>	∅ d <sub>1</sub>	∅ d <sub>3</sub>	∅ d <sub>5</sub>	g <sub>1</sub>	g <sub>2</sub>	s
мм								
MT 112	80	32	15,0	21,0	60	60	40,0	6,0
	100							
	125							
	160							
	200							
	250							
MT 160	100	37	18,0	25,0	70	70	45,0	7,0
	125							
	160							
	200							
	250							
	315							
MT 224	125	43	21,0	30,0	85	90	60,0	8,0
	160							
	200							
	250							
	315							
	400							
MT 315	160	48	25,0	36,0	100	100	65,0	10,0
	200							
	250							
	315							
	400							
	500							
MT 450	200	56	30,0	42,0	120	120	80,0	12,0
	250							
	315							
	400							
	500							
	500							
MT 630	250	66	36,0	50,0	140	140	90,0	14,0
	315							
	400							
	500							
	500							
MT 900	250	78	44,0	60,0	170	180	120,0	16,0
	315							
	400							
	500							
	500							

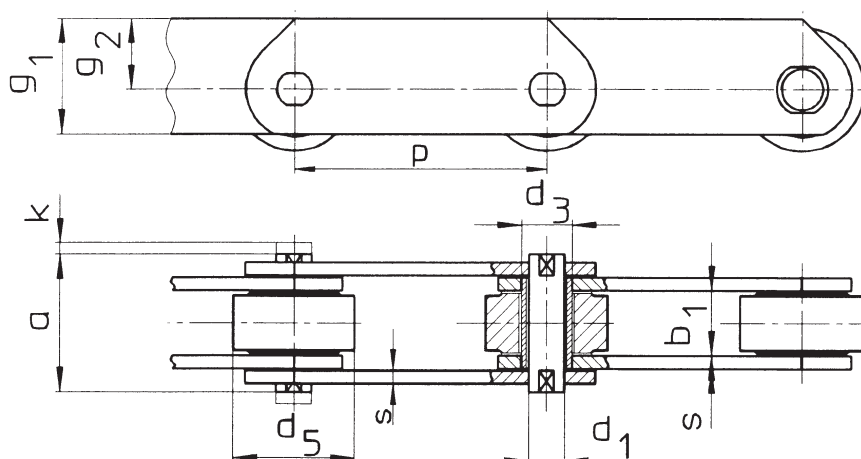

DIN- цепь №	Длина соед. заклепки а макс.	Выступ пальца с чекой к макс.	Предел прочности	Площадь шарнира	Удельное давление на шарнир, доп.	Вес
	мм		кН	см <sup>2</sup>	Н/см <sup>2</sup>	кг/м
MT 112	73	14,0	112	6,75	2370	17,51
						15,14
						13,24
						11,58
						10,39
MT 160	85	16,0	160	9,36	2440	9,45
						8,66
						23,03
						19,96
						17,28
MT 224	98	18,0	224	12,60	2540	15,36
						13,83
						12,56
						32,31
						27,72
MT 315	112	21,0	315	17,50	2570	24,44
						21,81
						19,64
						17,87
						41,52
MT 450	135	25,0	450	24,60	2620	36,36
						32,23
						28,82
						26,03
						56,92
MT 630	154	30,0	630	34,56	2610	50,06
						44,39
						39,76
						36,33
						75,88
MT 900	180	37,0	900	49,28	2610	66,58
						58,97
						53,33
						123,44
						107,30
						94,10
						84,33